

ROHN 45G TOWER BOOM OVERVIEW

- ### TOWER BOOM FEATURES
- UTILIZES APRS WORLD 2" SQUARE BOOM
 - EASILY ATTACHES TO TOWER WITH U BOLTS
 - SUPPORTS A 2" SQUARE TUBE BOOM FOR SENSORS
 - BRACKET WEIGHS ~5 LBS



SEE '2inBOOM' DATASHEET FOR DETAILS

ROHN 45G TOWER BOOM
BRACKET DIMENSIONS

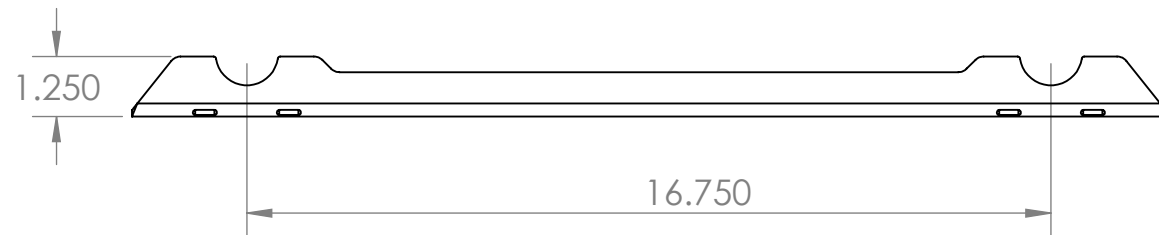
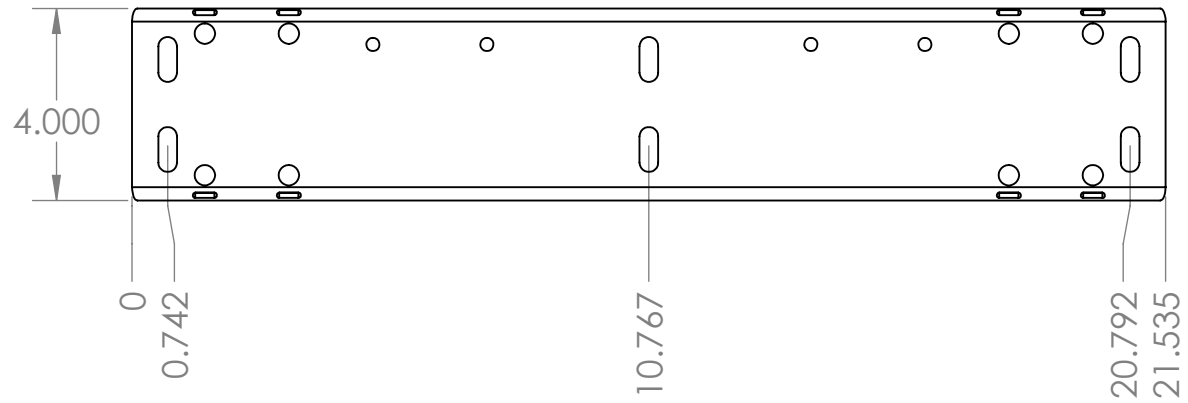
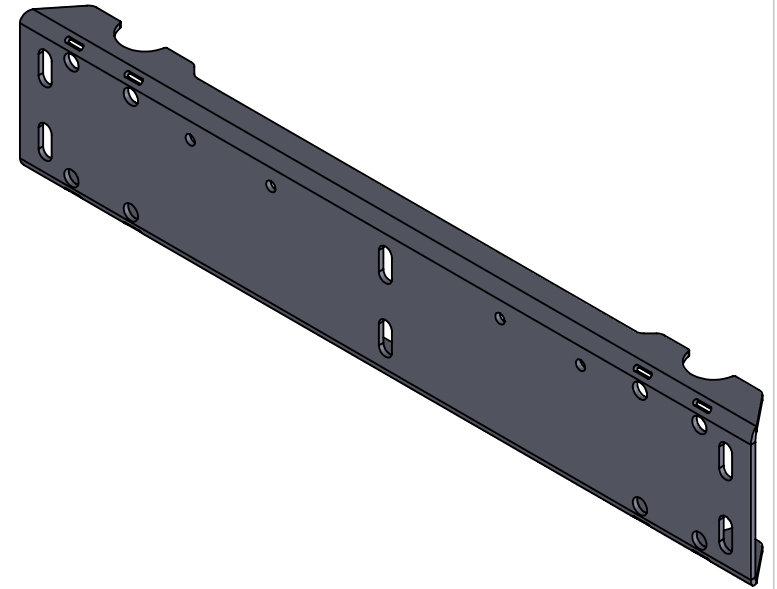

ROHN 45G TOWER BOOM INSTALLATION

ATTACH BRACKET

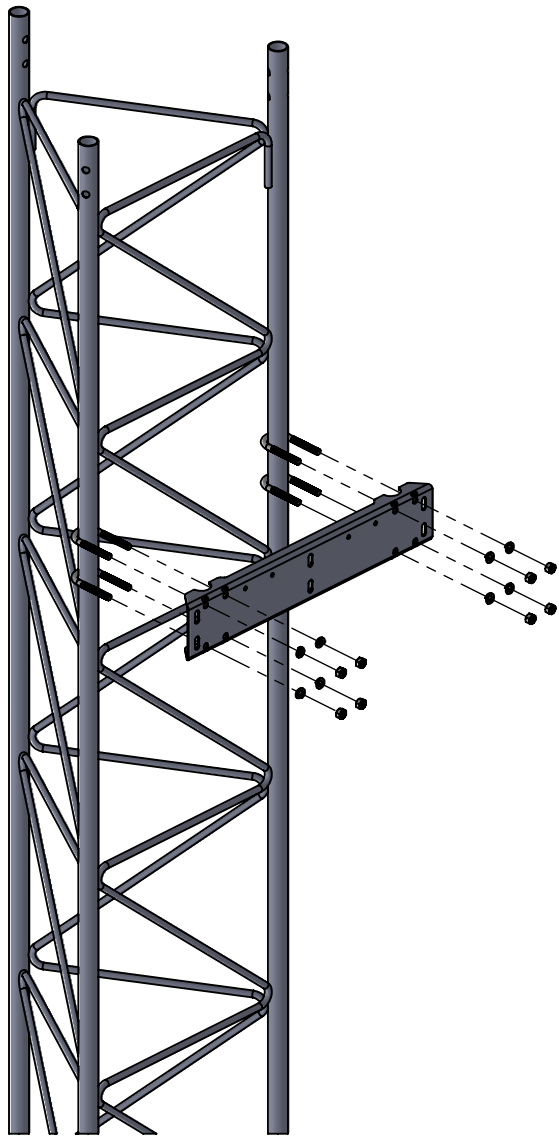

ATTACH BOOM

