

Version 4
May 2006

BWC XL.1 Tilt.Tower Installation Manual

18 m (59 ft) Tilt.Tower
24 m (78 ft) Tilt.Tower
29 m (97 ft) Tilt.Tower

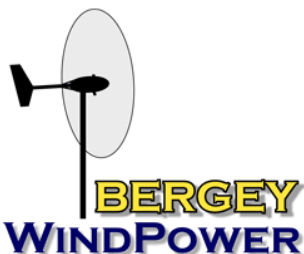
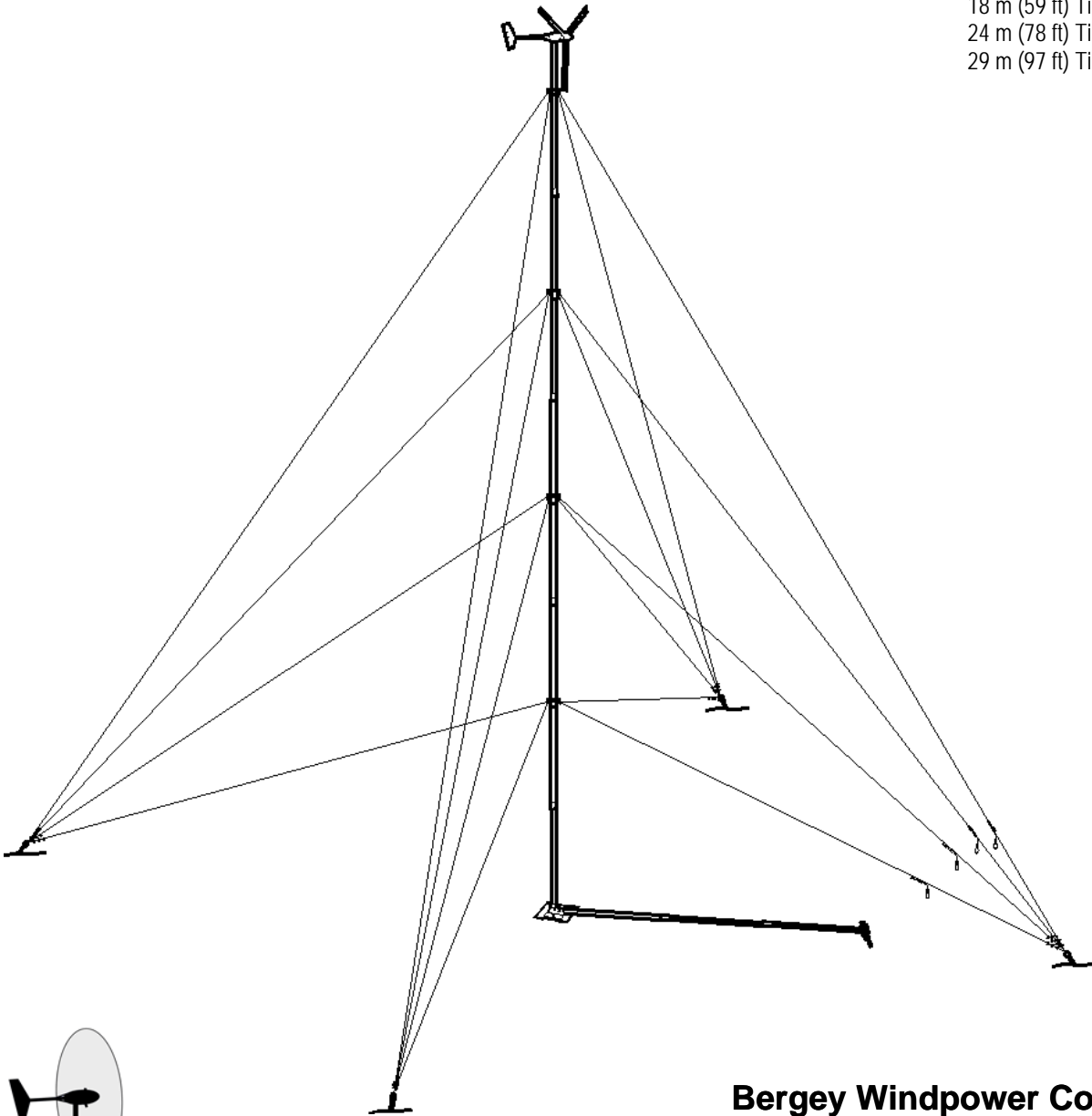

Bergey Windpower Co., Inc.

2200 Industrial Blvd.
Norman, OK 73069 USA
Telephone: (405) 364-4212
Fax: (405) 364-2078

E-mail: sales@bergey.com

Web: www.bergey.com

BWC Tilt-up Tower & BWC XL.1 INSTALLATION MANUAL

Table of Contents

1.	Overview	1
2.	Safety	2
3.	Cautions and Warnings	2
4.	Components	2
5.	Anchors and Base	2
6.	Tower Assembly	6
7.	Initial Tower Raising	10
8.	Tower Lowering	11
9.	XL.1 Wind Turbine	11
10.	Final Tower Raising	15
11.	Miscellaneous Reference Material	16
12.	Packing Lists	19

1. Overview

The Tilt.Tower is the factory recommended tower for the Bergey XL.1 turbine because it combines cost-effectiveness and ease of installation. Over the long-term the Tilt.Tower will also reduce “total costs of ownership” by making it easier for owners to inspect, provide preventive maintenance (particularly in corrosive environments), and perform repairs to the XL.1 wind turbine.

The Tilt.Tower kit includes all of the components and fasteners required to assemble and ground the tower. The tower can be installed without concrete work in areas with good soil strength and no rocks (that would impede the auger for the guy-wire anchors). In weak or rocky soils the use of concrete to fix the anchors is required. Proper grounding (or “earthing”) is an important element in protecting the system from lightning damage.

As shown in Figure 1, the tower is guyed in four directions. The tower is guyed at vertical intervals of approximately 20 ft (6 meters). The Tilt.Tower is best installed on level ground, but can be installed on slopes or uneven terrain provided that the base and the anchors on the tilt-axis can be kept fairly level. If this is not done, the tension in

the guy wires along the tilt-axis will change appreciably between the tilted-up and tilted-down positions. If the anchors are lower than the base the tension in the cable(s) can become excessive. If the anchors are higher than the base the cable(s) can become too loose to provide proper stability of the tower sections. When installing in sloped terrain, the Tilt.Tower should always tilt-down in the upslope direction.

After assembly of the tower, wind turbine, and tower wiring on the ground, the tower and turbine are tilted-up to the vertical position using a winch (not supplied) or a vehicle. A winch is preferred because of the greater control they afford.

The towers are provided with a lever arm, called a gin-pole, which runs from the base to one of the guy anchors. The gin-pole converts the pulling force on the pull-up rope or cable into a lifting force on the turbine and tower. Without the gin-pole it would be virtually impossible to raise the tower.

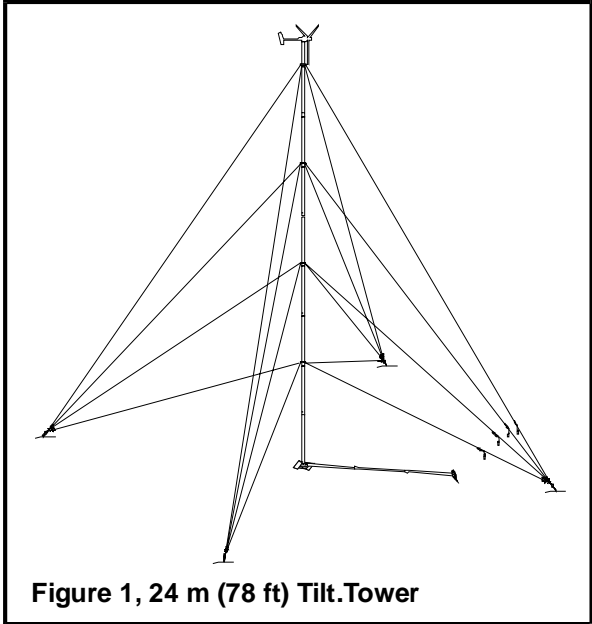

Figure 1, 24 m (78 ft) Tilt.Tower

2. Safety and Quality Assurance

The following recommendations should be carefully observed as part of any tower raising and lowering, and during the tower siting process. In particular, the safety of the crewmembers must be placed ahead of all other considerations. Some of the following warnings or cautions have been highlighted in the appropriate section of the manual.

1. DO read and follow the Tower Installation Manual.
2. DO NOT climb the tower.
3. DO NOT erect the tower near electric power lines.
4. DO NOT place guy anchors near roads, driveways, or normal paths for vehicles.
5. DO NOT permit unnecessary persons on the tower site while the tower is being raised or lowered.
6. DO NOT use a tractor or other vehicle to erect the tower without exercising extreme caution.
7. DO determine the soil type at your site and install the correct anchoring.
8. DO place tower anchors according to the anchor manufacturer's recommendations.
9. DO properly ground the towers electrically.
10. DO thoroughly understand the tower erection procedure before beginning the installation.

The Tilt.Tower is cost-effective, safe, and convenient; but the forces involved in raising and lowering are very large. Inadequate attention to proper rigging and procedures can lead to destruction of the equipment and/or serious injury. DO NOT cut corners or get into a hurry.

3. Cautions and Warnings

This manual contains important information on the installation of your Tilt.Tower, XL.1 wind turbine, and PowerCenter controller. We strongly recommend that you read and follow the instructions contained in this manual.

At several points in the manual items of special interest or significant impact are highlighted by one of the following notices.

Warning: Hazards or unsafe practices that could cause personal injury or death.

Caution: Hazards or unsafe practices that could cause product damage.

Note: Significant points of interest

4. Components

The major components for the tower kits are shown in Figure 2. The tower sections are 114 mm (4.5 in) diameter thin-wall steel tubes that have been swaged down at one end(except for end tubes) so they fit into each other. Every 6 m (20 ft) in height, which is two 3 m (10 ft) tower sections, there is a guy bracket with four 4.8 mm (3/16") diameter guy wires attached. These guy wires go out to four earth anchors and are attached with malleable clips. The top guy bracket attaches to the top tower tube mid-section.

The tower sections rest on a base plate assembly that often rests directly on the ground. The base plate also provides the pivots for the tower and gin-pole. The gin-pole is the lever arm used for raising and lowering the tower. It does not reach all the way out to the earth anchor in its direction, so a transfer of guy wires is necessary during raising and lowering. That is what the lifting eyes on the guy wires are for. The gin-pole has a teeter assembly at its end to accommodate the guy wires and the lifting line from the winch used for raising and lowering.

5. Anchors & Base Plate

Please review the Anchoring Reference section in Section 11 before proceeding further. Different soil conditions may require different anchoring methods to ensure proper strength.

Tools Required:

- 5-6 wood or metal stakes
- Hammer
- Sledge-hammer
- 100 ft. tape measure
- 6" Diameter x 5 ft. power auger
- Chance/Hubbell #C302-0003 10 ft Expanding & Tamping Tool or ~ 3 m (10 ft) long x ~ 75 mm (3") dia. heavy wall steel pipe
- Shovel
- 9/16" box-end wrench (or 14 mm)

9/16" socket and ratchet drive or 12" crescent wrench

Procedure:

Step 1:

Mark the ground location for the tower base plate, guy anchors, and the lifting anchor for the gin pole. The appropriate dimensions and ground layout are shown in Figure 3.

Make sure that you have sufficient room for the tower and turbine to tilt down. If you plan to mount solar modules on the tower we recommend

Hemisphere. If the site is not level, try to position the tower so that it will be lowered in the uphill direction. Check the diagonal distance between anchor points to ensure that they are "square".

Warning: The tower must not be erected near electric power lines. Most overhead power lines are not insulated, so they pose a life-threatening shock hazard.

Note: The side guy anchors and the base plate must be on a straight line to insure adequate cable tension during raising or lowering operations. If exact placement

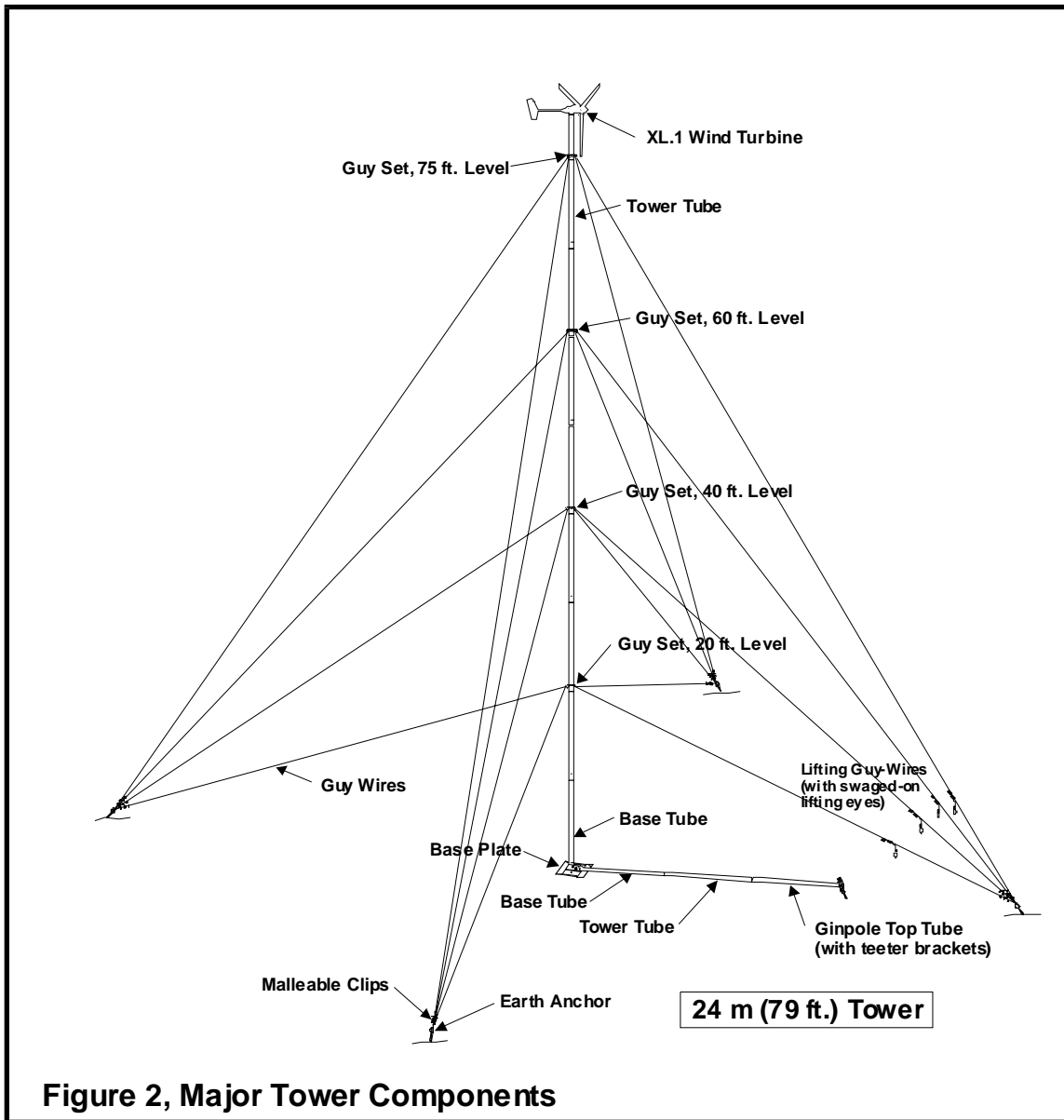

that the ginpole be oriented towards South in the Northern Hemisphere and North in the Southern

of an anchor point is not possible, it should be moved outward from the

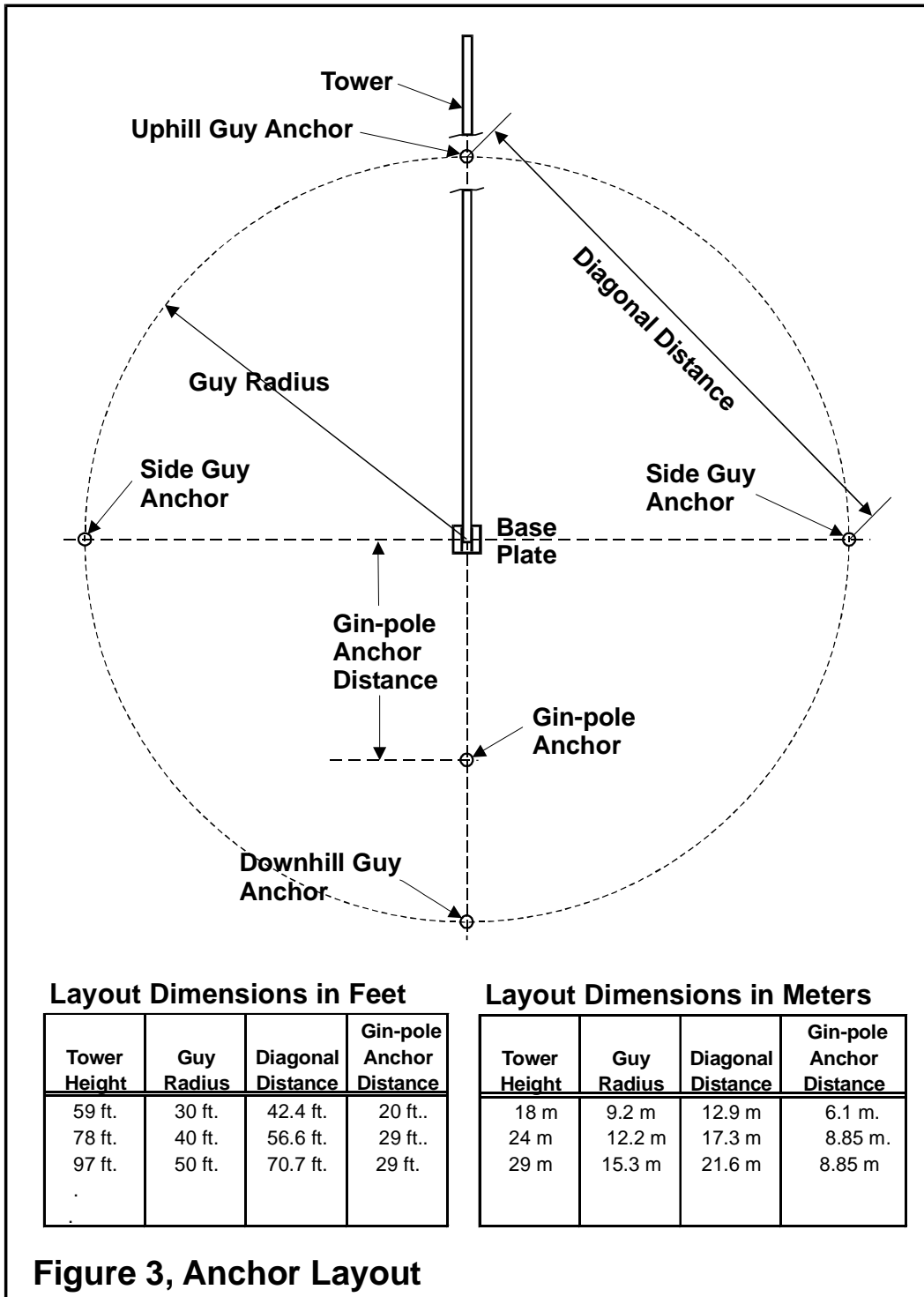

base rather than inward. Try to keep the side anchors and the base plate at approximately the same elevation

Step 2:

Refer to the A.B. Chance instructions below. At the four guy wire anchor stakes and the gin-pole anchor stake, auger 6" diameter holes at a ~ 45 degree angle oriented towards the tower base (center). The holes should be deep enough that

APPLICATION/INSTALLATION EXPANDING 8-WAY ANCHORS

ANCHOR APPLICATIONS	For distribution guying. Use to depths of 12 feet.
INSTALL IN THESE CLASS SOILS	Classes 3, 4, 5, 6 and 7 (100-600 inch-pound with the soil test probe)
INSTALLING EQUIPMENT REQUIRED	Hand or power auger. Expanding and tamping bar or mechanical tamper and shovel. (See page B-33)
LIMITATIONS ON USE	Depends on backfill effectiveness. Difficult to tamp in wet or plastic soil after rain. Seeping ground water can cut holding capacity 50 percent.

STEP #2

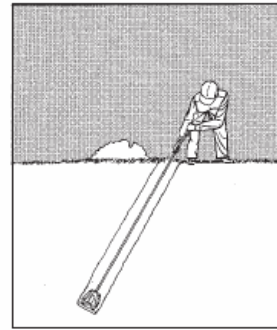

Attach rod to anchor and lower the assembly into the hole.

STEP #3

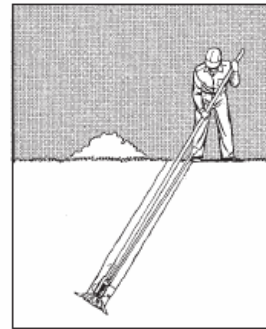

Expand the anchor with the expanding bar by striking the top plate.

NOTE: The expanding bar should be rotated around the anchor during the busting process.

STEP #4

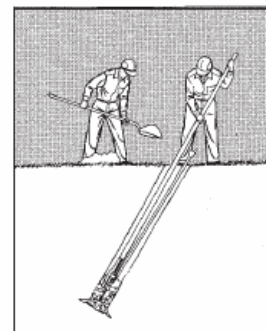

Backfill and tamp hole.

INSTALLATION GUIDE:

STEP #1

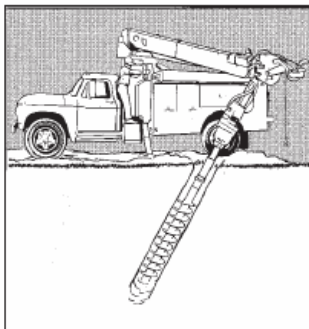

The hole should be drilled at a 45° to 60° angle in line with the guy.

NOTE: Hole size should be slightly larger than the unexpanded anchor. See chart on page B-17.

the anchor rod projects 4 – 6 inches above the surface when placed in the hole (without the bell attached).

Attach the rod to the anchor bell and insert in hole. Make sure it goes all the way to the bottom of the hole. Expand the bell anchor using the

Chance Expanding & Tamping Bar or a heavy pipe. Turn the Eye at the end of the rod so that it is oriented vertically so that the guy wires will attach in a straight vertical line. Make sure that the bell is fully expanded because its "bite" into virgin soil provides the primary strength of the anchor.

Refill the hole about 12" at a time, then carefully compacting the soil using a tamping tool. The fill must be compacted to develop proper strength and to keep water from seeping in and compromising the anchor strength.

For weak or problematic soils it may be necessary to use concrete for the anchors or use an alternate anchoring method. These topics are covered in Section 11, under Anchoring.

Step 3:

For most installations the base plate will sit directly on the ground. This is actually the preferred configuration. A concrete base is only needed when the soil strength is very low, such as sand or marsh.

Assemble the four piece base plate with the 3/8" x 1" stainless bolts, washers, and locknuts supplied with the kit as shown in Figure 4. To prevent galling, apply anti-seize compound to the bolt threads before screwing on the nuts.

Install the base plate with its up-turned flanges aligned with the tower lay-down direction. Sink the down-turned edges into the soil. Pound in the 8 ft (2.4 m) copper-clad ground rod through one of the two 7/8" holes in the base plate using a sledgehammer. Leave ~ 4 inches (10 cm) of rod above the Base Plate.

When using a concrete base for the tower we recommend a base that is roughly 60 cm x 60 cm x 30 cm deep (2 ft x 2 ft x 1 ft deep), with several pieces of steel reinforcing bar placed horizontally. Assemble the Base Plate with the Tilt Tower Base Plate must be secured to the concrete using two 5/8" hex head bolts (not supplied) or concrete anchor bolts (not supplied) installed through the 3/4" holes normally used for the ground rods.

You can either cast hex bolts into the concrete or pour the concrete pad and install anchor bolts after the pad has cured. Drilling the pad for anchor bolts will generally require the use of a hammer drill. For cast in bolts, we recommend two 6" long galvanized 5/8" diameter bolts with ~ 2 1/2" of the threaded end sticking up above the concrete. The bolts should be centered on the pad and spaced 17.7" apart. Note the tower tilt alignment direction required in Figure 4.

For non-concrete installations the channel plate that faces towards the gin-pole anchor should be

assembled in the extended position, as shown in Figure 4. When being bolted to a concrete pad the channel plate should be assembled in the retracted position. Securely bolt the Base Plate to the concrete pad. Install the ground rods adjacent to the concrete pad.

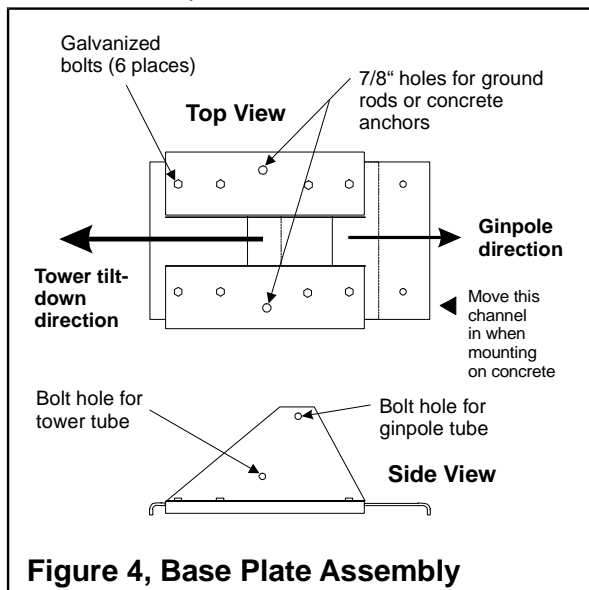

6. Tower Assembly

Tools Required:

- 1 1/4" box-end wrench or 18" crescent wrench
- 3/4" box-end wrench
- 7/16" box-end wrench
- 18" crescent wrench
- 12" crescent wrench
- 7/16" nut driver or socket w/ratchet
- Tape measure or rope
- Electrical tape

Procedure:

Step 1:

Bolt the base tower section to the base plate using a 3/4" diameter x 6 1/2" long bolt and nut through the hole drilled in the end of the base section. Use the lower hole in the center of the long base plate, as shown in Figure 4. Secure the 3/4" nut with a 3/4" pal-nut.

Note: If the power leads are to be carried inside the tower, as is recommended, they should be installed as the tower is

being assembled. See Section 9 for wire size recommendations.

Step 2:

Add one 3 m (10 ft) standard section to the base section for a total of 6 m (20 ft). Slide on the first guy ring (Labeled “20 ft. Level”) over the top of the swedged (reduced) section of the tube while the spooled guy wire sets are attached. Do not unspool the guy wires at this stage.

Slide the guy ring all the way down the swedged part of the tube to the “lip” where the tubes join. The ring will rest against the lip of the tube and the next tower tube will press against it. Make sure that the guy ring “ears” are facing towards the base plate.

Make sure that the guy wire spool with the free swedged thimble (lifting eye) is on the top. This thimble will attach to the gin-pole so it needs to be oriented towards where the gin-pole will be assembled.

Step 3:

Add two more 3 m (10 ft) sections and slide on the 40 ft level guys. Make sure that the guy ring “ears” are facing towards the base plate. Slide the guy ring down the swedged end of the tube to the lip where the tubes join. The ring will rest against the lip of the tube and the next tower tube will press against it. Do not unspool the guy wires at this stage.

Make sure that the guy wire spool with the free swedged thimble (lifting eye) is on the top.

Step 4:

On an 18 m (59 ft) tower, add one more 3 m (10 ft) section. Then loosely add the 3 m top section, which has eight threaded hole at its mid-section and six turbine mounting holes at its top. The turbine mounting holes must be at the top of the tower.

Add the Top Guy Bracket Collar, ensuring that the bracket ears face towards the base. Make sure that the guy wire spool with the free swedged thimble is on the top. Do not unspool the guy wires.

Attach the Collar to the top tube using six (6) ¼” x 1” stainless hex head bolts, after first applying Loctite to each bolt. A small tube of Loctite is

supplied in the tower kit. DO NOT apply anti-seize. Torque these bolts to 6.5 ft-lbs.

Adjust the angular alignment of the top tube so that the guy bracket ear of the spool with the free swedged thimble (lifting eye) is in line with the lower two brackets. Now the top tower tube can be fully pressed on.

Step 4-A (24 m towers only):

On the 24 m (78 ft) tower add one more standard section and then the top section as described in the previous paragraphs.

Step 4-B (29 m towers only):

On the 29 m (97 ft) tower, add two more 3 m (10 ft) sections and slide on the 80 ft level guy ring and wires. Make sure that the guy ring “ears” are facing towards the base plate. Slide the guy ring all the way down the swedged part of the tube to the “lip” where the tubes join. Do not unspool the guy wires at this stage.

Make sure that the guy wire spool with the free swedged thimble (lifting eye) is on the top.

Add one more standard section and then the top section as described in the previous paragraphs.

Step 5:

Roll out the side guy wires to the side anchors. Use a screwdriver or small diameter rod through the center of the wire spool as an “axle”. Let the wire unwind as you walk out to the anchor point.

Note: The guy wires with the lifting eyes must be on the upper side of the horizontal tower sections. This eye is clipped to the top of the gin pole. These guy wires serve as the lifting wires until the tower is fully erected.

Note: Guy wires must be rolled out to the anchors, not let out from a coil held in the hand or from the side of the spool. These latter two methods will allow the wire to become severely twisted and stressed, making it very difficult to handle.

Step 6:

When the guy wires are rolled out to all the anchors, check to insure that the tower is ~ 90 degrees with the line joining the side anchors and the base plate. If the anchors were accurately

placed the tower should lay close to the “uphill” anchor point (see Figure 3). If not, use a tape measure or a rope to check that the diagonal distances from the tower top to each side anchor are approximately the same. Check also that the front and rear anchors and the lifting anchor are in line with the tower.

Caution: Extra care must be taken while raising the tower if the anchor placement is not perpendicular (90 degrees) to the tower, or if the side anchors are not at the same elevation, or if the side anchors and base plate are not in a straight line. Any of these conditions will effect the guy wire tension as the tower is raised. Tension must be adjusted periodically as the tower is raised.

Step 7:

Assemble the 3/16” HD thimbles on the anchor rod eyes by twisting them open, pressing them on, and twisting them closed. Two crescent wrenches work well for this task. There will be 3 thimbles per anchor on the 18 m (59 ft) tower, 4 thimbles per anchor on the 24 m (78 ft) tower, and 5 thimbles per anchor on the 29 m (97 ft) tower.

Slide three wire rope malleable clips (supplied in the guy set box) onto each guy wire end. Place the wire rope clips on the wire so that the forged, grooved part cradles the wire coming from the tower (the “tension side”) and the “U-bolt” part clamps down on the end-most section of the wire. Thread the guy wire end through the anchor rod eye and around a thimble, double back and slide through the first wire rope malleable clip.

The guy wires are wrapped around the anchor eye thimbles as shown on the anchor detail in Figure 5. Leave a little slack in the guy wire. Snug up the wire rope malleable clips using a 7/16” nut driver. Tighten two of the clips. Let the other clip remain loose until the tower has been erected and leveled.



Figure 5, Guy Wire Attachment

Step 8:

Referring to Figure 4, the gin pole will attach to the base plate with a 3/4” diameter x 6 1/2” long bolt. The ginpole is assembled in the same direction as the tower itself, with the ginpole resting on top of the tower sections. Secure the 3/4” nut with a 3/4” pal-nut.

The following procedure integrates the assembly of the gin pole safety wire (see Figure 6), which will keep the gin pole from coming apart when the load direction changes during tower raising:

1. Assemble gin pole – align holes at each end
2. Slide safety wire inside gin pole.
3. Assemble gin pole on top of tower.
4. When bolting gin pole to base plate, pass bolt through loop in safety wire.
5. When assembling gin pole brackets at the outer end of the gin pole, pass bolt through loop in safety wire.

The 18 m (59 ft) tower uses a ~ 20 ft. gin pole, made up of two 10 ft. sections. The 24 m (79 ft) and 29 m (97 ft) towers use a ~ 29 ft gin pole, made up of three 10 ft sections.

The safety wire has three thimbles attached, one at each end and one ~ 9 ft. from the end. Use the two thimbles at the ends for the 24 and 29 m towers. Use one end thimble and the intermediate thimble for the 18 m tower.

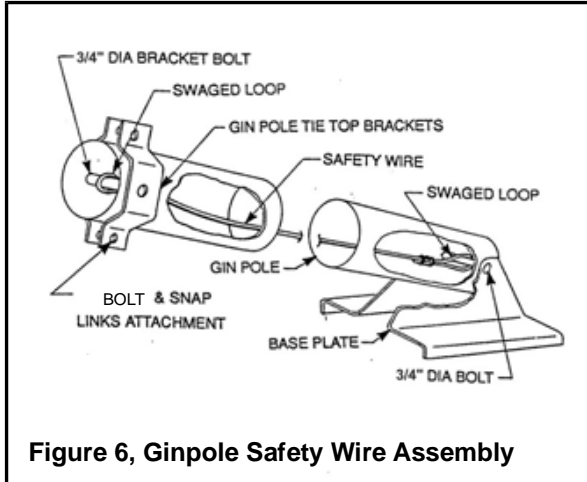

Figure 6, Ginpole Safety Wire Assembly

Make sure that the bracket bolt in the end section of the gin pole is aligned as shown in Figure 6. Bolt the gin-pole brackets to the end section with the 3/4" bolt, making sure to pass the bolt through the safety wire thimble. Secure the bolt with a 3/4" nut and Pal-Nut.

Attach the snap link to the gin-pole bracket with a 1/2" bolt. A snap link is a heavy galvanized steel or stainless steel loop with a spring-loaded gate or opening side bar. Be sure that the snap link opens down and away from the base plate. This will allow the lifting guy wires to be clipped and unclipped in the correct order.

Step 9:

Roll out each level of the lifting guy wires and attach each of the swaged-on lifting eyes to the snap links shackled to the bracket at the end of the gin pole. The top guy wire attaches to the forward snap link. The lower guy(s) are clipped to the second snap link, the lowest guy wire first. Make sure that the guy wires are not twisted. The free ends of the remaining guy wires will be attached to the forward anchor after the tower is erected. Keep the wires well organized so this will be easy to do.

Step 10:

Attach the two yellow polypropylene ropes to the top of the gin pole. Run one of the ropes to each of the side anchors. The ropes prevent the gin pole from falling sideways when vertical, and center it as the tower is being raised.

Step 11:

Attach the cable from the lifting device to the gin pole tie top bracket with a shackle from the hardware kit. Electric or hand winches may be used.

The pull-up forces (including the XL.1 turbine) and the pull-up cable lengths are given below:

Height, meters	Height, feet	Pull-up Force, kgs (lbs)	Pull-up Cable Travel, meters (ft)
18	59	340 (750)	9.1 (30)
24	78	520 (1,150)	13.1 (43)
29	97	700 (1,550)	13.1 (43)

These loads are static loads. Bouncing or shock loading can cause higher momentary loads. We recommend using at least 3/16" steel wire rope for the lifting. We also recommend a 2:1 pulley block arrangement to reduce the line tension for the 25 and 32 meter towers. A 2:1 pulley block will cut the pull-up force in half. The pulley block is attached to the ginpole shackle or snap-link. Please remember that using a 2:1 pulley will double the pull-up cable travel to 27 m (86 ft) on the taller towers.

Warning: If a winch is used we strongly recommend that a worm-gear type be used and that a spur-gear type be avoided. A worm-gear winch is inherently self-locking and cannot free-spool like a spur-gear type winch.

Bergey Windpower offers manual winch kits that are rigged and ready to go. The kit is shown in Figure 7. Contact your dealer or Bergey Windpower for information and pricing.

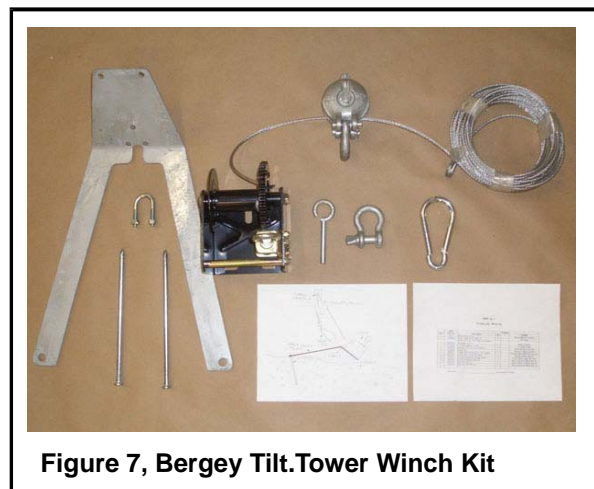

Figure 7, Bergey Tilt Tower Winch Kit

Caution: If using a tractor or truck, extreme care must be exercised. Use a pulley block at the lifting anchor. Never attach a cable from a truck/tractor directly to the gin pole end. Proceed slowly and smoothly.

Step 12:

Walk the gin pole toward the vertical position while taking in the slack with the lifting device. When the gin pole is nearly vertical, all the lifting wires should be tight. If using a drum winch, try to guide the cable onto the drum so that it is distributed evenly across the surface of the drum.

Step 13:

Use some tape to secure the tower electrical wiring at the top end of the tower so that it will not slide down the tower when the tower is raised.

Step 14:

Lift the tower 1.2 m to 1.8 m (4 ft to 8 ft) above the ground to check the operation of the lifting device and the security of the lifting and guy cables. The side guy wires must be tended to prevent the tower from bowing or falling off to one side or the other. In addition to checking the security and adjustment of the guy wires, check the lifting anchor for movement. If the gin pole anchor will not hold, the soil is too poor for this type of anchor or the depth of the anchor was insufficient. The maximum lifting force is experienced when the tower is first lifted from the ground.

Warning: Do not work under or near the tower while it is being lifted. Do not work under or near the tower when it is off the ground, unless it is resting on blocks or is fully guyed.

Step 15:

Lower the tower and make any necessary adjustments to the guy wires or anchors. Roll out the guy wires that will be attached to the back anchor located under the tower pole. Attach the set of back guy wires to the back anchor. The back guy wires should be walked over to the side anchors to get an approximate length prior to attachment.

7. Initial Tower Raising

At this stage, an initial tower raising without the wind turbine in place is recommended. It will in-

sure that all the cables and anchors are secure, that the lifting procedure is satisfactory, and will allow the back guy wires to be attached and adjusted. The sequence is shown in Figure 7.

Tools Required:

7/16" nut driver

Procedure:

Step 1:

Start lifting the tower 10° to 20° at a time. Monitor the side guy wires and the yellow gin pole ropes carefully. They may become either loose or tight if the site and the anchor points are not perfectly level. Although there must be some tension in the wires at all times to provide side support for the tower, there must always be visible slack in the guy wires. If no slack is visible, the tension is too great. Over-tension may cause failure of the wires, the anchors, or the tower. For further information, refer to the section on SLACK at the end of the instructions.

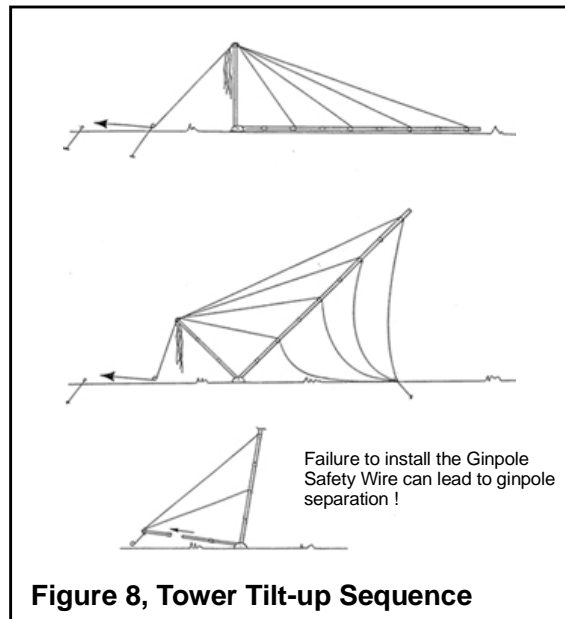

Figure 8, Tower Tilt-up Sequence

Adjust the cable tension as required using the wire rope clips. Work slowly. Fast uneven movements tend to make the tower swing or waver. Try to work smoothly and insure that those people tending the cables are able to follow along with the tower raising process.

Caution: Be sure that communication between all members of the lifting team is clear and concise.

Note: The guy wires can be pulled in by one person when the winch is stopped. Brute force is not required.

Step 2:

As the tower approaches vertical, it is important to maintain tension on the back guy wire set. This should be done by standing to one side of the anchor, not directly under the tower, pulling on ropes attached to the guy wires. All back guy wires should be held, allowing the raising device to pull against the tension until the tower is vertical or the gin pole is on the ground.

Note: The tower will lift easily at this point. Very little force is required to lift the tower into its final position.

Step 3:

Check the side guy wire tension for a moderate degree of slack, corresponding to a wire pull of about 23 kilograms (50 pounds). Check the security of the wire rope clips.

Maintaining tension on the lifting cables with the raising device, use a carpenter's level on the base tube to adjust the guy wires until the base tube is vertical. Insure that the tower is straight by sighting up the tower while the final guy adjustments are being made.

For this initial lift, it will not be necessary to transfer the lifting guy wires from the gin pole to the forward anchor.

8. Lowering the Tower

The procedure is just the reverse of raising the tower, although certain precautions must be taken.

Step 1:

If the raising process has indicated that the tension of the side guy wires will vary as the tower is being lowered, it is important that the side guy wires be tended to avoid excessive tightening or slackening.

WARNING: At no time during the lowering operation should personnel, vehicles, or other equipment be located where they could be hit by the tower or the side guy

wires. Determine the boundaries of the potentially dangerous area and keep it clear.

Step 2:

Tension must be applied to the back guy wires to pull the tower away from the raising device as it begins letting out cable. In order to clear the danger area, it will be necessary to apply the tension through ropes attached to the guy wires. The ropes should be attached above the back anchor and should be long enough to insure that personnel are located well beyond the point where the top of the tower will touch the ground when lowered. Pull as required to keep tension on the guy wires.

As the tower is lowered and reaches an angle between 60° and 45°, it will no longer be necessary to maintain tension on the guy wires opposite the winch.

Step 3:

Set the tower down on blocks placed about every 6 m (20 ft) along the tower.

Step 4:

Ground the tower base by installing the ground clamp to one of the ground rods and attaching one end of the bare copper grounding wire. Attach the other end of the grounding wire, using a small loop, to one of the 3/8" tower base plate bolts.

9. Installing the XL.1 Wind Turbine

XL.1 Wind Turbine Components

The major components of the XL.1 wind turbine are shown in Figure 9. Installing the turbine requires connecting it to electrical wiring to the PowerCenter controller and then assembling the turbine at the top end of the tower.

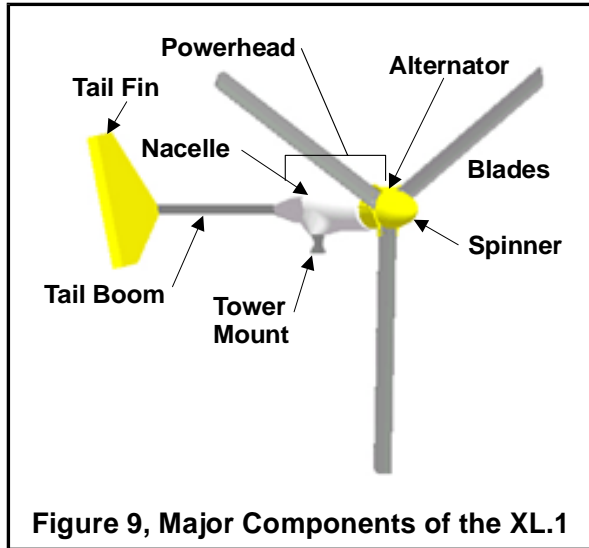

Figure 9, Major Components of the XL.1

Wiring

The basic electrical schematic for the BWC XL.1 battery charging system is shown in Figure 10.

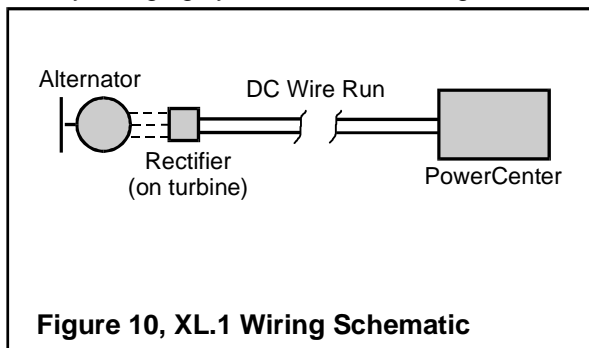

Figure 10, XL.1 Wiring Schematic

The wind turbine alternator produces a 3-phase AC, which is rectified into DC up in the nacelle. A two (2)-conductor wire is needed between the wind turbine and the PowerCenter controller. The PowerCenter has a DC circuit breaker for the wind turbine input, so no fused-disconnect switch is required at the base of the tower (as is recommended for the other BWC wind turbines).

In some cases it will be possible to provide direct point-to-point wiring between the XL.1 wind turbine and the PowerCenter. For this purpose we recommend 2-conductor VNTC (Vinyl Nylon Tray Cable), which is suitable for outdoor and direct-burial applications. For rocky soils we recommend that the underground wire run be installed in conduit. If a wiring junction is made at the base of

the tower then a watertight junction box should be installed for the connections.

The recommended wire sizes for the 24 VDC XL.1 wind turbine are shown in Table 2. The listed distances include the height of the tower.

Maximum Current: 60 amps

Caution: Installing wire sizes larger than those recommended will increase the maximum current produced by the turbine.

Table 2: Recommended Wire Sizes for the XL.1

Distance	Size (U.S.)	Size (metric)
23 m (75 ft)	#8 AWG	8.4 mm ²
46 m (150 ft)	#6 AWG	13.3 mm ²
69 m (225 ft)	#4 AWG	21.2 mm ²
91 m (300 ft)	#4 AWG	21.2 mm ²
114 m (375 ft)	#2 AWG	33.6 mm ²
130 m (450 ft)	#2 AWG	33.6 mm ²

Note: These wire sizes have been engineered to provide optimum rotor loading for the BWC XL.1/24 wind turbine. Deviation from these recommendations can result in decreased performance from your machine and / or unnecessary additional wire-run costs. The use of a wire gage one size larger than the recommended size is acceptable and is recommended if aluminum wire is used.

Turbine Installation

The fasteners on the XL.1 are all metric.

Tools Required:

- 17 mm box end wrench
- 17 mm socket and ~ 12" ratchet drive
- 8 mm socket or wrench
- pliers
- crimpers for wiring terminals (U-shaped crimp preferred over straight crimp)
- thread locking compound (like Loctite 242)
- tape measure, 12 ft.

Procedure:

Step 1:

Place the powerhead of the wind turbine near the top end of the tower.

The tower wiring is connected to the XL.1 wind turbine at the slip-ring using the two small screws on the positive and negative slip ring terminals. The best way to do this is with ring terminals chosen for your tower wire type. The polarity of the connections is marked. If your conductors are color-coded we recommend making note of the colors connected to positive and negative leads.

The slip ring assembly is not designed to support the weight of the down-tower wire. A strain relieving installation is required, as shown in Figure 11. Use the two nylon cable ties provided to secure the tower wiring to the tower adapter casting. After completing the connections, pull on the tower wire to make sure that it is secure before mounting the wind turbine on the tower.

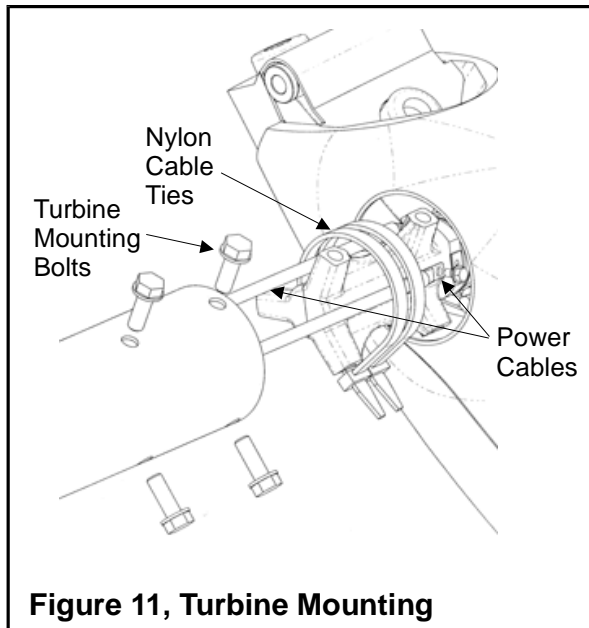

Figure 11, Turbine Mounting

Step 2:

Raise the tower about 1 meter (3 ft) off the ground to provide room to assemble the XL.1 turbine. We recommend fashioning a temporary support stand to hold the tower up during turbine assembly.

Step 3:

Mount the wind turbine tower adapter to the top of the tower using the six M10 x 1.5 bolts and six lock washers. We strongly recommend applying Loctite 242 (Thread Locking Compound) to the

threads prior to installation to reduce the likelihood of loosening due to vibration. We recommend using a torque wrench to achieve the proper fastener torque on the tower mounting bolts. The recommended torque is 47 N.m (35 ft-lbs).

On the 19-32 m (64-104 ft) towers the larger diameter of the tower tubing means that spacers are added to the inside of the top section to provide the proper fit-up for the wind turbine.

Step 4:

Complete the wiring to the PowerCenter before adding the blades. This is recommended so that you can test the DC polarity of the wiring by spinning the alternator by hand. It is very important that the polarity [positive (+) and negative (-)] is correct when the turbine is connected to the PowerCenter. The best way to ensure this is to complete the wiring and then test the polarity with a Volt-Ohm-Meter. Turning the alternator by hand will provide enough voltage to make this check. Carefully mark the positive and negative electrical leads for later reference.

Step 5:

Turn the XL.1 powerhead upward so that the alternator is facing up. Attach the blades as shown in Figure 12 using the M10 hardware provided. We recommend bolting one blade up solidly and leaving the other two somewhat loose while you check the tip-to-tip blade distance. We recommend checking, and adjusting as necessary, the blade tip spacing to ensure that the blade tips are equally spaced. This step will help make the wind turbine as smooth running as possible, which will maximize the operating life of the bearings and reduce vibration related noise. The blade tip-to-tip distances should not differ by more than 12 mm (1/2") for smooth operation.

We recommend using a torque wrench to achieve the proper fastener torque on the blade nuts. The recommended torque is 47 N.m (35 ft-lbs). Loctite is not necessary on the blade fasteners because the nylon locking nuts provide adequate locking.

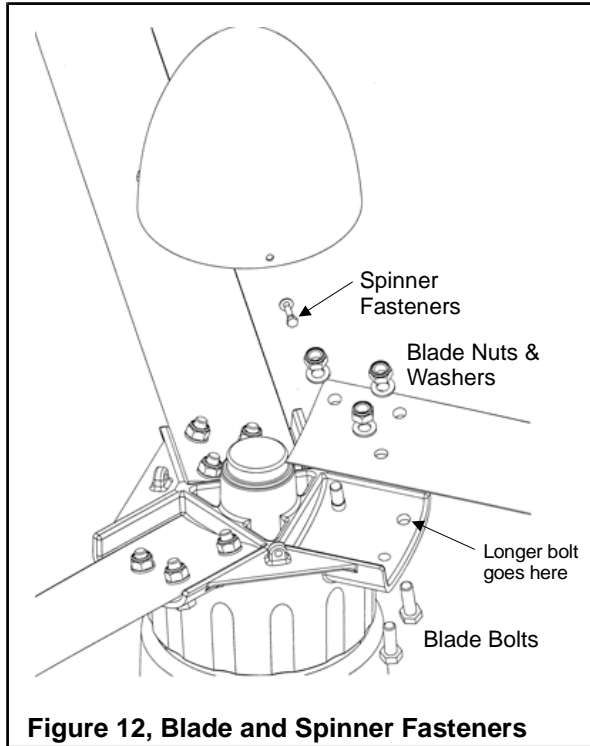

Figure 12, Blade and Spinner Fasteners

Step 6:

Attach the spinner (nose cone) using the three M5 bolts and lock washers provided, as shown in Figure 12. We recommend applying Loctite to the bolt threads prior to assembly.

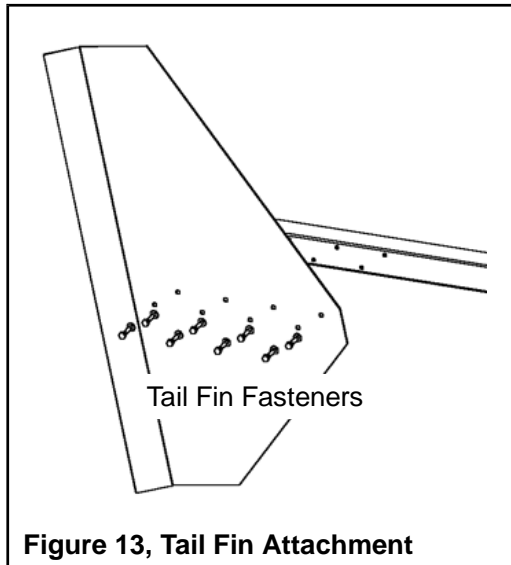

Figure 13, Tail Fin Attachment

Step 7:

Bolt the tail fin to the tail boom using the eight M5 bolts and lock-washers provided, as shown in

Figure 13. We recommend applying Loctite to the bolt threads prior to assembly.

Step 8:

Place the tail boom on the rear of the turbine powerhead and insert the 12 mm (1/2") tail pivot pin from the top. If the parts are aligned properly the pin should insert easily. Do not use a hammer to pound the pin in place, as this may cause scoring of the bronze bushings. Secure the tail pivot pin with two cotter pins, as shown in Figure 14. Failure to properly install and secure both cotter pins will lead to loss of the tail boom.

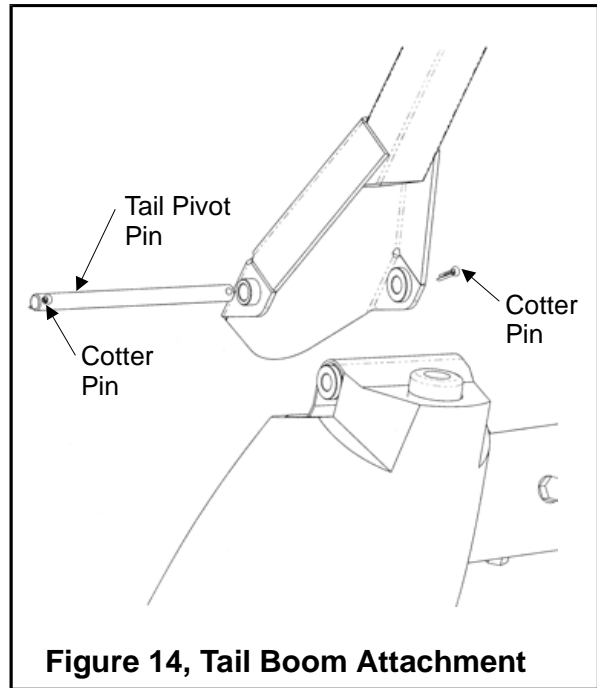

Figure 14, Tail Boom Attachment

Step 9:

Check the XL.1 wind turbine carefully to make sure that the installation is complete. We recommend the following checklist:

- Blade fasteners are secure and properly torqued
- Blade tips are evenly spaced
- Spinner is secure
- Tail fin is secure
- Tail pivot pin is locked in place with both cotter pins.
- Tower adapter bolts are secure
- Wiring polarity is tested and marked

10. Final Tower Raising

Tools Required:

7/16" nut driver (several)

Procedure:

Step 1:

Short-circuit the XL.1 alternator by twisting or bolting the output wires together. This will keep the wind turbine from spinning during the raising of the tower. If the PowerCenter connections have already been made this can be easily done by moving the positive lead over to the negative terminal.

Step 2:

Follow Steps 1 through 3 of the **Initial Tower Raising** instructions in Section 7.

Step 3:

Transfer the lifting guy wires one at a time from the gin pole to the forward anchor, as shown in Figure 15. Secure each wire with wire rope clips, being sure to maintain tension on each cable as it is transferred. Start with the top level and work down.

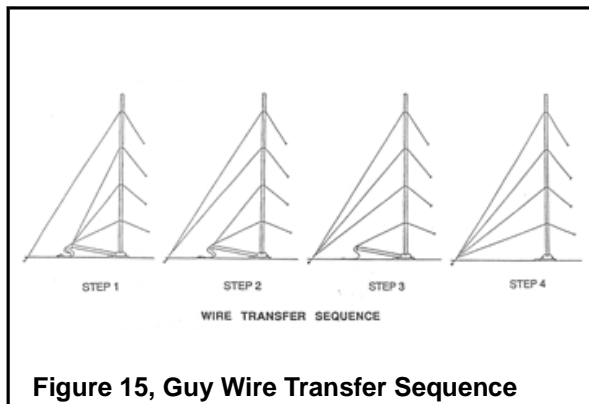

Step 4:

Again, use a carpenter's level on the base tube to check that the tower is vertical in all directions. Make a final adjustment of all guys to insure that the tower is straight. On the taller towers this may take some time due to the number of wires involved.

Step 5:

Pull all guy wires tight by hand with approximately 45 kg (100 lbs) pounds tension. Tighten the second and third wire rope clips on each guy wire.

There will be a small amount of visible slack in all guy wires. This is normal.

Step 6:

Check the guy wires in 2 or 3 weeks and tighten as required. Depending on the soil type, it may require one or more checks and adjustments before the tower and anchors have fully settled.

Installation instructions for the PowerCenter controller are provided in the XL.1 Owners Manual.

11. Misc. Reference Material

Anchoring

For most installation sites the 6" diameter expanding anchors supplied with the Tilt.Tower kits will be perfectly adequate. In some cases the soil will either be too weak for proper strength or too "hard" for augering the hole. In these cases, a subsurface concrete pad can usually be substituted. In the case of hard rock, however, special rock anchors may be necessary. This reference section is designed to provide you with considerations and recommendations that will ensure that you install adequate anchors.

The installation of guy wire anchors is a critical element in the installation of the tower. The anchoring system must be able to withstand, without appreciable creep, the steady and vibratory loads of the guy wires through all weather conditions for the life of the installation. Site conditions will dictate the type of anchoring system used. Soil type, water level, freeze depth, and weather variations all have an effect the holding capacity of the anchors.

Soil Types & Conditions

Most anchoring systems are designed to work in a limited range of soil conditions. To choose the proper anchoring system, it must be possible to identify these various soils. The accompanying Table 2 shows a system of soil classification developed by the A. B. Chance Company on the basis of the mechanical properties of the soil.

Table 2: Soil Classifications

Class	Common Soil-Type Description	Geological Soil Classification
0	Sound hard rock, un-weathered	Granite, Basalt, Massive Limestone
1	Very dense and/or cemented sands; coarse gravel and cobbles	Caliche, (Nitrate-bearing gravel/rock)
2	Dense fine sand; very hard silts and clays (may be preloaded)	Basal till; boulder clay; caliche; weathered laminated rock
3	Dense clays, sands and gravel; hard silts and clays	Glacial till; weathered shales, schist, gneiss, and sandstone
4	Medium dense sandy gravel; very stiff to hard silts and clays	Glacial till; hardpan; marls
5	Medium dense course sand and sandy gravels; stiff to very stiff silts and clays	Saprolites, residual silts
6	Loose to medium dense fine to course sand; firm to stiff clays and silts	Dense hydraulic fill; compacted fill; residual soils
7	Loose fine sand; Alluvium; loess; soft-firm clays; varied clays; fill	Flood plain soils; lake clays; adobe; gumbo; fill
8	Peat, organic silts; inundated silts; fly ash	Miscellaneous fill, swamp marsh

Used by permission of A. B. Chance Co.

The presence of water reduces the holding strength of the anchors. Anchor creep can be a problem in soils with large variations in moisture content. If this condition can occur, it is best to ensure that the bearing surface of the anchor be placed below the level of periodic surface saturation.

If an anchor is located above the depth to which the ground freezes, it may experience a phenomenon known as “freeze-throw” or “jacking”. This is the tendency of buried objects to be pushed toward the surface by the freeze-thaw cycles. To avoid this problem, the bearing surface of the anchors must be placed below the level to which the ground freezes. In areas of permafrost, the anchors should be below the permafrost line. Provisions should be made to prevent solar energy from being transmitted down the rod. If you must anchor within the permafrost zone we recommend using the services of a local contractor with expertise in artic / cold climate anchoring.

Anchor Rods

All the anchoring systems described in the following sections use a galvanized steel rod to connect the guy wire to the bearing surface of the anchor. The rod ends form an “eye”, which provides an attachment point for the guy wires.

The anchor rods should be installed at an angle that will minimize the bending loads acting on them. The angle for the BWC XL.1 towers should be approximately 45 degrees, with the eye of the anchor rod toward the tower.

Anchor Types and Their Installation

Three types of anchoring systems may be used to accommodate various soil types: screw-in / expanding anchors, sub-surface concrete pads, and expanding or bonded rock anchors.

Screw Anchors / Expanding Anchors

In most areas of the country, power-installed screw anchors have become the standard anchoring system used by the utilities. Screw anchors were furnished as standard equipment with earlier versions the BWC XL.1 towers. They were intended to be installed manually with a stout bar through the eye or with a hand-held electric drive. We have switched to Chance 8-Way Expanding Anchors because they can be used in a broader range of soil conditions. The expanding anchors included with the tower are suitable for installation in Soil Classes 3 - 6, and in some Class 7. If there is any doubt about the quality of the soil, consider other anchoring options or consult the factory.

Concrete Anchors

A second option is to dig a hole about 0.75 m (2.5 ft) square to a depth of at least 1.2 meter (~ 4 ft). You should move the centerline of the hole you will dig back ~ 1 m (40”) away from the center of the tower to account for angle of the anchor rod.

Place the anchor as shown in Figure 16 (note: previous screw anchors are shown) and fill the bottom of the hole with concrete to a depth of at least 0.3 meters (1 ft), covering the bell and part of the rod. It is not necessary to expand the expanding anchors, but you need to “shake” the anchor during the concrete pour to free trapped air. Reinforcing rods should be incorporated in the

concrete so as to provide adequate strength and load distribution in the pad.

The backfilled earth should be tamped vigorously as it is returned to the hole.

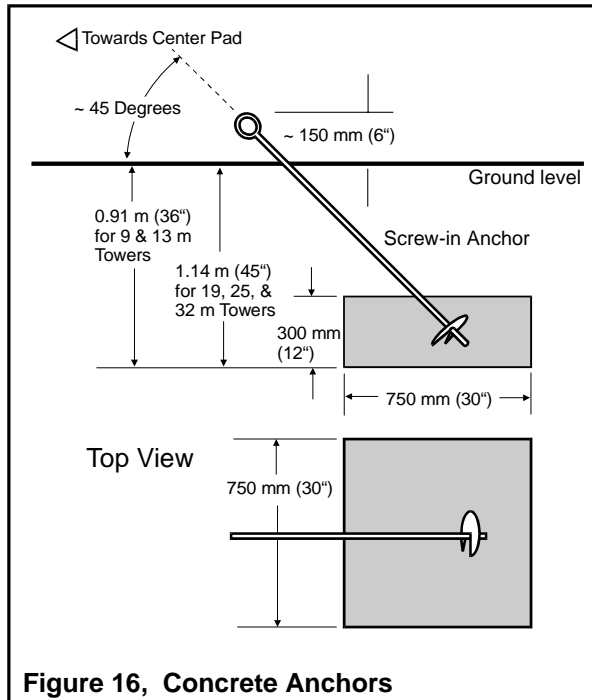

Figure 16, Concrete Anchors

Other anchor rod configurations may be used with a concrete pad, but the size and depth of the pad must be at least as large and as deep as shown. The anchor rod and its attachment to the foot that is to be imbedded in the pad must have at least the strength of the anchor supplied with the tower kit.

Rock Anchors

Expanding rock anchors or bonded rock anchors are the best choice for Class 0 and Class 1 soil. Rock drilling is hard and tedious work. It requires special equipment, including a compressor and air drill. When needed, rock anchors should be installed by, or with the advice and assistance, of a local contractor familiar with this type of anchor. In all cases, the recommendations of the anchor manufacturer should be followed. Bergery Windpower can also provide advice on rock anchoring.

Customer-Supplied Anchor Rods

The oval eye anchors supplied by BWC allow guy wire thimbles to be installed, preventing sharp

bends in the guy wires. Any alternative anchor rods should incorporate similar provisions.

Guy Wires

Guy Wire Slack

There must be visible slack in all guy wires during all phases of tower installation. It is possible to have too much slack or too little slack. The following discussion is aimed at defining these conditions.

Unless the anchors are placed precisely in their correct locations and the site is perfectly level, some guy wires will tighten and some will loosen as the tower is raised or lowered. For this reason, all guy wires must be watched and adjusted as needed throughout the tower raising or lowering process.

When a guy wire loses its slack and becomes tight, there is no easy or obvious way to tell how much tension there is in the wire. A wire that becomes tight can quickly apply a very large force on both the anchor and the tower to which it is attached. If the tower lifting or lowering process is continued, the force may increase to the point at which the tower will buckle, causing it to fall and endanger people, vehicles, or equipment nearby.

When the tower has been assembled and is first lifted slightly off the ground to test the winch anchor, the lifting wires running from the top of the gin pole to the tower should be studied. They will all have a certain amount of droop or slack. Studying the tower's top lifting wire will give all members of the lifting crew a good idea of slack. Make sure that the side guy wires have noticeably more slack than this reference wire. They should not, however, appear sloppy. A droop greater than three or four feet should not be allowed to develop during the raising/lowering procedure.

The tower should have no more than a gentle bend from base to top. If the bow becomes more than about one foot, the side guy wires or the lifting wires should be adjusted before proceeding further.

This sequence of observing, communicating observations, issuing commands to guy tenders, adjusting guys, and retightening wire rope clips must be well understood by all members of the team before lifting or lowering starts. It is a con-

tinuing process throughout the lifting/lowering sequences. Particular care should be taken at sites where guy wires might catch on tree limbs, roots, rocks, or other obstructions.

A guy wire will have about 23 kilograms (50 pounds) of tension when the tower is properly erected. This amount of tension is a comfortable but hearty pull on the wire for an average crew member. The uppermost guy wire will have one foot to two feet of droop with 23 kilograms (50 pounds) of tension. Letting out just six inches of the top guy wire will add approximately two feet of droop to the wire and will cause the tower to move over a few inches at the attachment point.

Tower Lift Crew

The following is a suggested guide to forming an efficient and safe crew to erect a BWC XL.1 tower.

Four members:

1. One member to operate the winch and serve as the key person or leader.
2. Two people to attend to and adjust each side guy anchor. These individuals must be familiar with taking in and letting out guy wires.
3. One person free to assist in holding or pulling guy wires as required. This person should also continuously observe the guy wires and the entire lifting operation for any unusual or dangerous situations.

Warnings

The following warnings should be carefully observed as part of any tower siting and raising or lowering operation. Some of the following warnings or cautions have been highlighted in the appropriate section of this manual.

1. Read and follow the TOWER INSTALLATION MANUAL
2. DO NOT climb the tower.

3. DO NOT erect the tower within 1 1/2 times the tower height of electric power lines.
4. DO NOT place guy anchors near roads, driveways, or normal paths for vehicles.
5. DO NOT permit unauthorized persons on the tower site while the tower is being raised or lowered.
6. DO NOT use a tractor or truck to erect the tower without exercising extreme caution.
7. DO determine the soil type at your site and install the correct anchors.
8. DO place tower anchors according to the anchor manufacturer's recommendations.
9. DO properly ground the tower electrically.
10. DO thoroughly understand the tower erection procedure before beginning the installation.

YOU MUST BECOME FAMILIAR with all components of the tower, including hardware, and how they function, before attempting to install the tower. Tall guyed towers can be dangerous and you or members of your crew could be injured or killed.

Tilt.Tower Packing Lists

BWC XL.1 Series

Packing List, HKGT4-60, Guyed Tilt-up Tower, 58.5 ft (18m)

Shipped to: _____

Item	BWC Part No.	Description	Qty	No. Packed	USAGE
1	6613	Top Tower Section	1		Section
2	6610	Standard Tower Section	4		Section
3	6611	Base Tower Section	1		Section
4	6611	Gin Pole Inner Section	1		Gin Pole
5	6620	Gin Pole Outer Section	1		Gin Pole
6	6616	Tower Base Channel	2		Base
7	6617-RH	Tower Base Bracket, Right Hand	1		Base
8	6617-LH	Tower Base Bracket, Left Hand	1		Base
9	6618	Gin Pole Cable Bracket	2		Gin Pole
10	6619-1	Guy Bracket & Guy Wire Assembly, 39'	1		Guys
11	6619-2	Guy Bracket & Guy Wire Assembly, 51'	1		Guys
12	6619-3	Top Guy Bracket & Guy Wire Assembly, 64'	1		Guys
13	HB4010	1/4" x 1" Hex Head Bolt	6		Guys
14	HW4001	1/4" Flat Washer	6		Guys
15	HB6002	3/8" x 1" Bolt	8		Base
16	HW6004	3/8" Washer, SS	16		Base
17	HN6008	3/8" Nylock Nut, SS	8		Base
18	HBB030	3/4" x 6 1/2" Bolt, Tower & Gin Pole Pivots	2		Tower & Gin Pole
19	HBB030	3/4" x 6 1/2" Bolt, Gin Pole Shackle	1		Gin Pole
20	HNB011	3/4" Nut, A536	3		Tower & Gin Pole
21	HNB008	3/4" Pal Nut	3		Tower & Gin Pole
22	HB8021	1/2" x 2 1/4" Bolt, Shackle to Snap Link	1		Gin Pole
23	HB8021	1/2" x 2 1/4" Bolt, Shackle to G.P. Anchor	1		Gin Pole
24	HN8007	1/2" Nylock Nut, SS	2		Gin Pole
25	6621	Gin Pole Safety Cable	1		Gin Pole
26	HM3002	3/16" Maleable Clip, HDG	36		Guys
27	HM3001	3/16" HD Thimble	12		Guys
28	HM0008	5/8" x 8' Grounding Rod	2		Grounding
29	HM0042	5/8" HD Ground Rod Clamp	2		Grounding
30	11471-2	Ground Cable Assembly	2		Grounding
31	HM0018	6" Dia. Expanding Anchor	5		Anchoring
32	HMA003	5/8" x 7' Anchor Rod	5		Anchoring
33	HO0006	Snap Link	1		Raising
34	6622	Nylon Guy Rope	1		Raising
35	SF0081	Loctite Compound	1		Guys
36	HM0040	Antisieze Compound	1		Base & Gin Pole

Packed By: _____

Latest Revision: 5/4/06

BWC XL.1 Series

Packing List, HKGT4-80, Guyed Tilt-up Tower, 77.5 ft (24m)

Shipped to: _____

Item	BWC Part No.	Description	Qty	No. Packed	USAGE
1	6613	Top Tower Section	1		Section
2	6610	Standard Tower Section	6		Section
3	6611	Base Tower Section	1		Section
4	6611	Gin Pole Inner Section	1		Gin Pole
5	6610	Gin Pole Standard Section	1		Gin Pole
6	6620	Gin Pole Outer Section	1		Gin Pole
7	6616	Tower Base Channel	2		Base
8	6617-RH	Tower Base Bracket, Right Hand	1		Base
9	6617-LH	Tower Base Bracket, Left Hand	1		Base
10	6618	Gin Pole Cable Bracket	2		Gin Pole
11	6619-4	Guy Bracket & Guy Wire Assembly, 47'	1		Guys
12	6619-5	Guy Bracket & Guy Wire Assembly, 58'	1		Guys
13	6619-6	Guy Bracket & Guy Wire Assembly, 73'	1		Guys
14	6619-7	Top Guy Bracket & Guy Wire Assembly, 86'	1		Guys
15	HB4010	1/4" x 1" Hex Head Bolt	6		Guys
16	HW4001	1/4" Flat Washer	6		Guys
17	HB6002	3/8" x 1" Bolt	8		Base
18	HW6004	3/8" Washer, SS	16		Base
19	HN6008	3/8" Nylock Nut, SS	8		Base
20	HBB030	3/4" x 6 1/2" Bolt, Tower & Gin Pole Pivots	2		Tower & Gin Pole
21	HBB030	3/4" x 6 1/2" Bolt, Gin Pole Shackle	1		Gin Pole
22	HNB011	3/4" Nut, A536	3		Tower & Gin Pole
23	HNB008	3/4" Pal Nut	3		Tower & Gin Pole
24	HB8021	1/2" x 2 1/4" Bolt, Shackle to Snap Link	1		Gin Pole
25	HB8021	1/2" x 2 1/4" Bolt, Shackle to G.P. Anchor	1		Gin Pole
26	HN8007	1/2" Nylock Nut, SS	2		Gin Pole
27	6621	Gin Pole Safety Cable	1		Gin Pole
28	HM3002	3/16" Maleable Clip, HDG	48		Guys
29	HM3001	3/16" HD Thimble	16		Guys
30	HM0008	5/8" x 8' Grounding Rod	2		Grounding
31	HM0042	5/8" HD Ground Rod Clamp	2		Grounding
32	11471-2	Ground Cable Assembly	2		Grounding
33	HM0018	6" Dia. Expanding Anchor	5		Anchoring
34	HMA003	5/8" x 7' Anchor Rod	5		Anchoring
35	HO0006	Snap Link	1		Raising
36	6622	Nylon Guy Rope	1		Raising
37	SF0081	Loctite Compound	1		Guys
38	HM0040	Antisieze Compound	1		Base & Gin Pole

Packed By: _____

Latest Revision: 5/4/06

BWC XL.1 Series

Packing List, HSGT4-100, Guyed Tilt-up Tower, 96.5 ft (29m)

Shipped to: _____

Item	BWC Part No.	Description	Qty	No. Packed	USAGE
1	6613	Top Tower Section	1		Section
2	6610	Standard Tower Section	8		Section
3	6611	Base Tower Section	1		Section
4	6611	Gin Pole Inner Section	1		Gin Pole
5	6610	Gin Pole Standard Section	1		Gin Pole
6	6620	Gin Pole Outer Section	1		Gin Pole
7	6616	Tower Base Channel	2		Base
8	6617-RH	Tower Base Bracket, Right Hand	1		Base
9	6617-LH	Tower Base Bracket, Left Hand	1		Base
10	6618	Gin Pole Cable Bracket	2		Gin Pole
11	6619-8	Guy Bracket & Guy Wire Assembly, 55'	1		Guys
12	6619-9	Guy Bracket & Guy Wire Assembly, 65'	1		Guys
13	6619-10	Guy Bracket & Guy Wire Assembly, 77'	1		Guys
14	6619-11	Guy Bracket & Guy Wire Assembly, 93'	1		Guys
15	6619-12	Top Guy Bracket & Guy Wire Assembly, 106'	1		Guys
16	HB4010	1/4" x 1" Hex Head Bolt	6		Guys
17	HW4001	1/4" Flat Washer	6		Guys
18	HB6002	3/8" x 1" Bolt	8		Base
19	HW6004	3/8" Washer, SS	16		Base
20	HN6008	3/8" Nylock Nut, SS	8		Base
21	HBB030	3/4" x 6 1/2" Bolt, Tower & Gin Pole Pivots	2		Tower & Gin Pole
22	HBB030	3/4" x 6 1/2" Bolt, Gin Pole Shackle	1		Gin Pole
23	HNB011	3/4" Nut, A536	3		Tower & Gin Pole
24	HNB008	3/4" Pal Nut	3		Tower & Gin Pole
25	HB8021	1/2" x 2 1/4" Bolt, Shackle to Snap Link	1		Gin Pole
26	HB8021	1/2" x 2 1/4" Bolt, Shackle to G.P. Anchor	1		Gin Pole
27	HN8007	1/2" Nylock Nut, SS	2		Gin Pole
28	6621	Gin Pole Safety Cable	1		Gin Pole
29	HM3002	3/16" Maleable Clip, HDG	60		Guys
30	HM3001	3/16" HD Thimble	20		Guys
31	HM0008	5/8" x 8' Grounding Rod	2		Grounding
32	HM0042	5/8" HD Ground Rod Clamp	2		Grounding
33	11471-2	Ground Cable Assembly	2		Grounding
34	HM0018	6" Dia. Expanding Anchor	5		Anchoring
35	HMA003	5/8" x 7' Anchor Rod	5		Anchoring
36	HO0006	Snap Link	1		Raising
37	6622	Nylon Guy Rope	1		Raising
38	SF0081	Loctite Compound	1		Guys
39	HM0040	Antisieze Compound	1		Base & Gin Pole

Packed By: _____

Latest Revision: 5/4/06